

COMPLAINT

SECONDARY COMPLAINT

Pump stator bushings worn beyond service limits

- Excessive turbine shaft-to-stator bushing clearance

CAUSE

Wear associated with normal use causes bushing failure.

CORRECTION

The Sonnax bi-metal bushing restores correct shaft/bushing clearance and resists wear.

Pump Stator Bushings

120003K

1 Large Bushing
1 Small Bushing

120003-TL

1 Removal Tool

Note: This tool will remove pump stator bushings from both Renault DPO and Citroen AL-4 transmissions without damage to the bore.

Also available

120003-01

1 Small Bushing

120003-02

1 Large Bushing

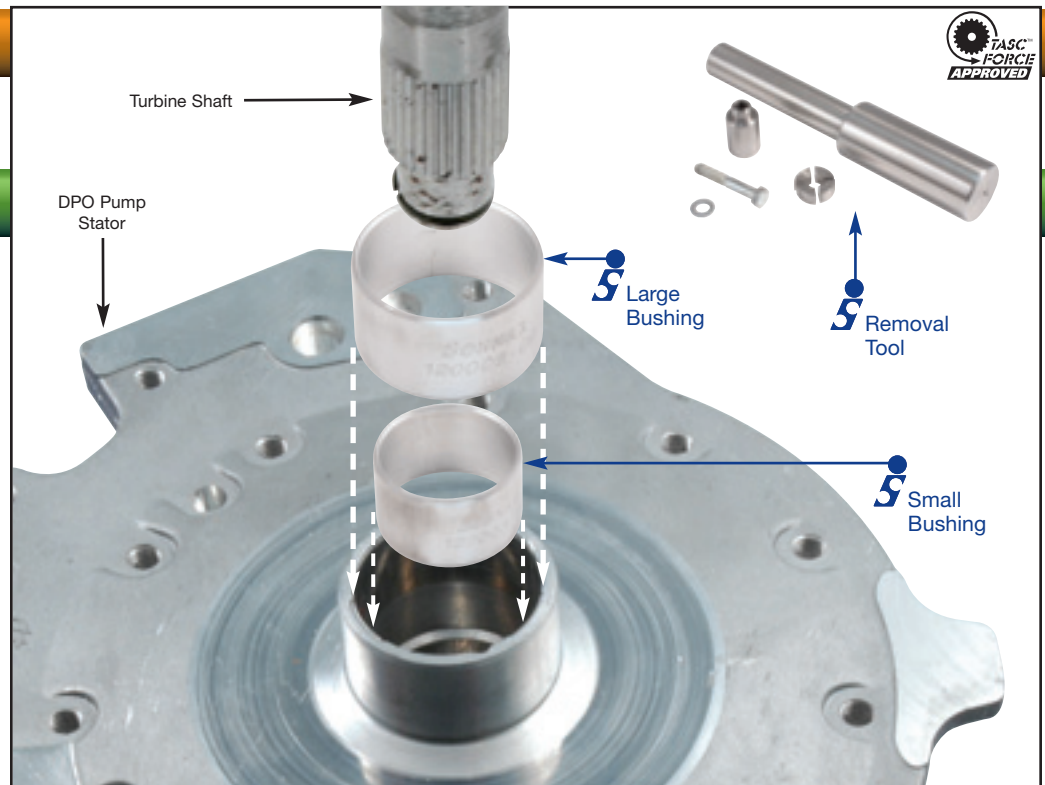

Sonnax Part Summary

The pump stator bushings in Renault DPO and Citroen AL-4 transmissions are prone to wear from normal operation, and are difficult to remove without damaging the housing bore I.D. Sonnax offers an improved pump stator bushing kit **120003K** and removal tool **120003-TL** to allow easy bushing removal without damaging the bore.

Features & Benefits

- Bushings are made from steel-backed aluminum alloy for better wear resistance.
- Precision-fit bushings do not require machining.
- Tool allows removal of old bushings without scoring or damaging the housing bore I.D.
- Bushings also available separately.

Save \$300 in pump replacement costs

