

COMPLAINT

Planetary failure, shaft breakage

CAUSE

Poor tolerancing of the OEM bushings allows critical lube to exhaust.

CORRECTION

These unique replacement bushings restore the desired fit with the underdrive shaft to prevent excessive radial movement.

Overdrive Clutch Hub Bushing

92004-LOS Housing I.D. Size .9410
5 Bushings Late Design

92004-L Housing I.D. Size .9370
5 Bushings Late Design

92004-SP Housing I.D. Size .9590
5 Bushings Early Design

Note:

92004-LOS is for the later design (1996 & up) 41TE, 42LE Housing Dia. .9410

92004-L is for the later design (1996 & up) 41TE, 42LE Housing Dia. .9370

92004-SP is for the early design (1995 & earlier) 41TE Housing Dia. .9590

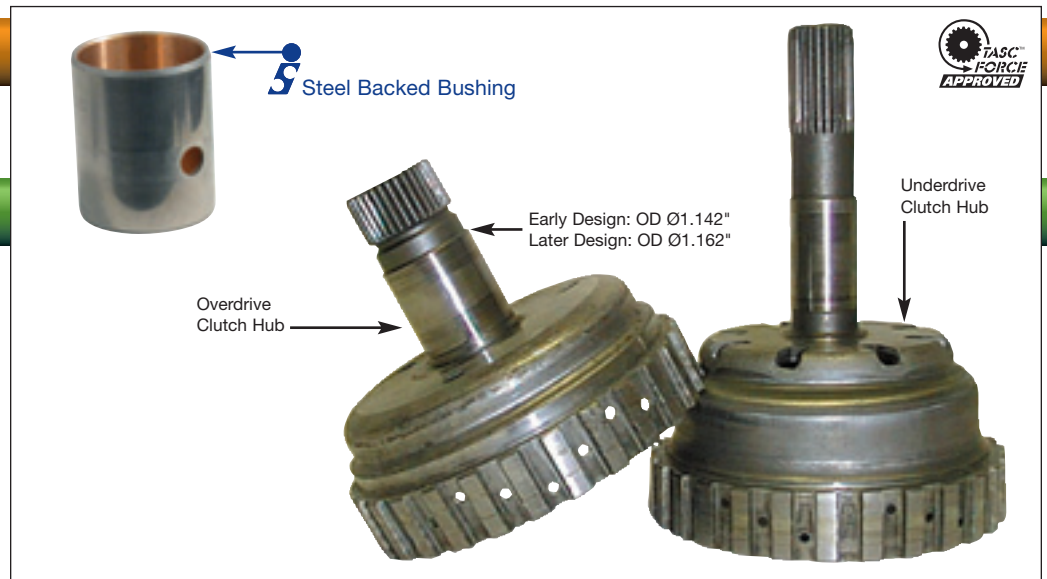

Sonnax Part Summary

The OEM overdrive clutch hub bushings in 41TE and 42LE units are poorly toleranced and allow leakage that can lead to lube exhaust and planetary damage. The Sonnax replacement bushings **92004-L**, **92004-LOS** and **92004-SP** replace the two-piece OEM bushing and provide a more closely toleranced fit.

Features & Benefits

- Closely toleranced, one-piece steel-backed bushings press into the overdrive clutch hub shaft to restore desired fit with the underdrive shaft.
- Better fit prevents excessive radial movement.
- Cross hole in the Sonnax replacement bushings aligns with the cross hole in the overdrive shaft to allow oil passage.

92004-L, 92004-LOS, 92004-SP, OD CLUTCH HUB

