



TORQUE CONVERTER PARTS

AL-WA-2

STATOR CAP/BEARING ADAPTER (IMPELLER SIDE)

Applications:

- Allison 1000/2000/2400, 2006 & Earlier

Details:

- Adapts late-model impeller side bearing **AL-N-1** to earlier applications
- Replaces OEM impeller-side stator cap
- Manufactured from billet or forged wear-resistant aluminum alloy

Associated Parts:

- **AL-N-1**, Enclosed Thrust Bearing
- **AL-90-3G**, Impeller Hub/Bearing Adapter (Available 2008)

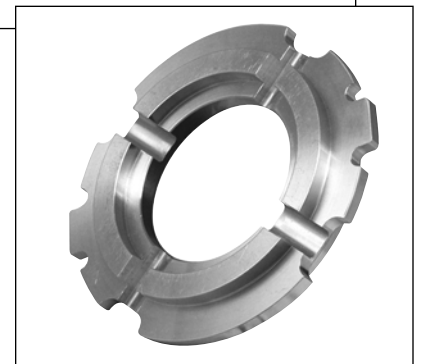

Part No.

AL-WA-2

Stator Cap/Bearing Adapter

Sold in prepackaged quantities of 10 units

Please refer to our

TORQUE CONVERTER PARTS CATALOG VOLUME 6 & ONLINE CATALOG AT WWW.SONNAX.COM

AL-WA-2 is:

Item Number 7 for Allison 1000/2000/2400 on page 40.

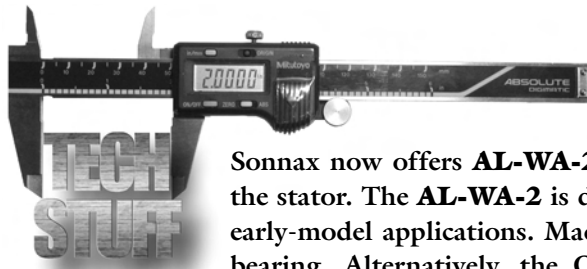

Sonnax now offers **AL-WA-2**, an aluminum stator cap/bearing adapter for the impeller side of the stator. The **AL-WA-2** is designed to adapt the late-model impeller bearing **AL-N-1** for use in early-model applications. Machining of the OEM impeller hub is required to accept the **AL-N-1** bearing. Alternatively, the OEM impeller hub may be replaced entirely with the **AL-90-3G** impeller hub, coming in 2008.